

Kalisiak Stanisław, Barzyk Grzegorz
Technical University of Szczecin
Institute of Electrical Engineering

SIMPLE AND SAFE WIND POWER PLANT SYSTEM COOPERATING WITH STATIONARY NETWORK

Key Words: wind power plants, electronic power control systems, thyristor applications, fuzzy logic

Abstract: The Authors of the paper present a cheap however reliable wind power plant operating system working for stationary, stiff network. The paper presents the comparison of some parameters of respective systems used nowadays, indicating their main disadvantages and technical difficulties in constructing them. The reasons to provide the research on the construction of wind power plants in Western Pomerania (Poland) have been presented by showing the characteristics of wind speeds measured in Szczecin surroundings within the period 1987-1996. On base of analysis of the solution proposed the Authors have suggested the algorithm of system control using the multi-function microprocessor adjustment with an option of fuzzy logic operation.

1. INTRODUCTION

The cost of construction of standard wind power plant of capacity up to 0.5 MW equals to approx. 850 ECU per 1 kW (world statistics). Even if in fact the price of Polish construction appears to be lower by 30% against comparative west constructions, the cost significantly exceeds the financial capability of an average investor in Poland and other countries of the former Eastern Block. However, there is no doubt that at power crisis forecast and intensive attempts aiming at finding alternative ecological energy resources the wind energy might be excluded.

According to many estimations and opinions the wind energy cannot be commonly used due to relatively low wind power obtained particularly on areas distant from sea coast. However, against those opinions, in the regions situated relatively far off the sea, e.g. in Berlin or Nurnberg in Germany, quite many wind sites generating electric energy have been constructed. They deliver the power supply both to autonomous receivers and those working for stationary power network. Basing on the data available at the Institute of Meteorology and Water Management in Gdynia, Poland [5] the authors have elaborated the characteristics of wind occurrence frequencies including wind speed in Szczecin Region within the period from 1987 till 1996 (Fig.1). This characteristics as well as an example characteristics of the relation between the power of wind generator of vertical rotation axis and the speed of the wind (Fig.2), elaborated by the Authors of this paper in cooperation with the constructors of generator mentioned above [8], have clearly proved the possibility of utilization of wind power plants within the Western Pomerania Region, even if wind generators of vertical rotation axis are considered less efficient (e.g. see [6]) per area unit than the horizontal rotation axis generators.

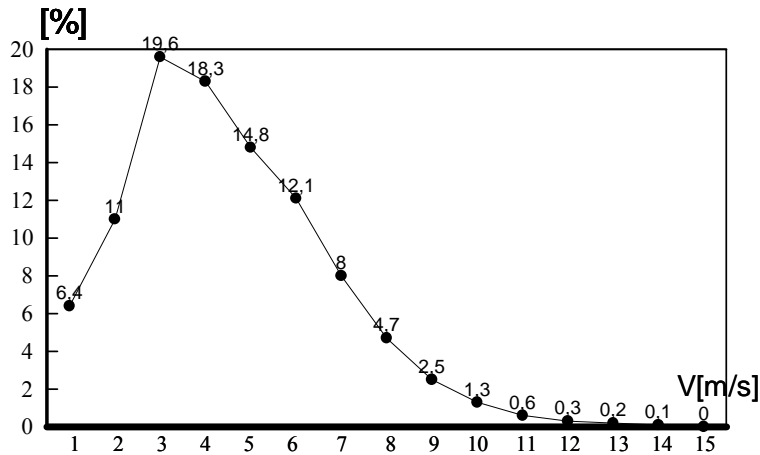

Fig.1 Frequencies of occurrence of particular wind speeds in Western Pomerania Region (Poland) within 1987-1996

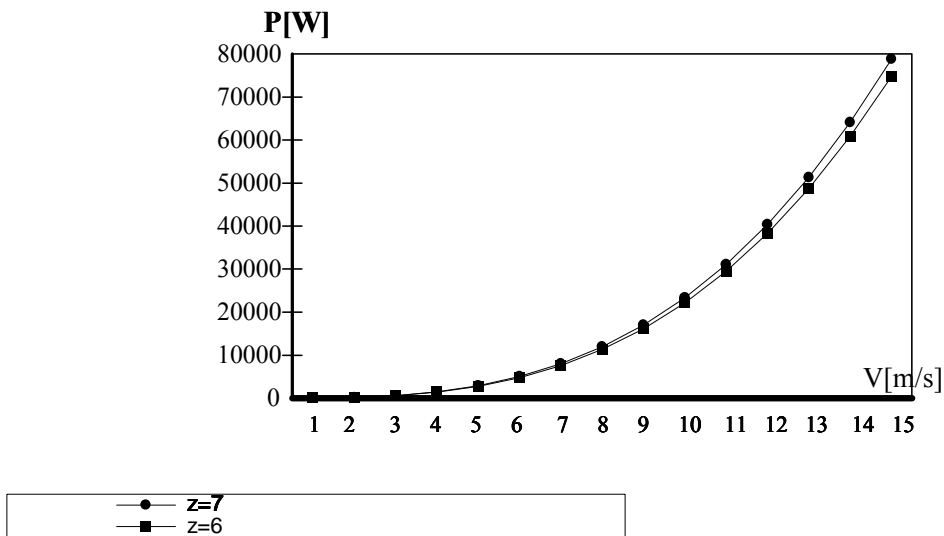

Fig.2 Relation between the capacity of vertical rotation axis wind generator and the wind speed, at two standard high-speed rates.

2. WIND POWER PLANT OPERATING SYSTEM

To reduce the overall costs of wind power plant investment, producers of wind power plants, sparging on the safety of the latter, consciously avoid using the most advanced and most expensive but still not guaranteeing failure free operation solutions. In broadly available publications [1,3,4,6] one can find a lot of wind power plant operating systems. However, those solutions include several misconceptions that appear further on either in design phase or during technical realization of the system.

A typical example is the wind power plant operating system making use of multi-run asynchronous machines as generators [1]. One of the most essential problems of this system is the procedure of switching of the number of pole pairs and the phenomena arising thereby and affecting the process of commutation formation to obtain the optimum capacity coefficient (e.g. transient states, power underloading on switching). Except for the above the other problems may occur there, e.g. coming with torque to plant's bottom (problem: great mechanical loss on the long shaft) or placing the machine on the top (problem: damaging dynamic moments in case of great wind speed).

Another system, involving the use of an asynchronous ring engine in cascade system with extremal adjustment [4], despite some undoubtful advantages engages in several disadvantages excluding practical applications of that system, e.g. the necessity to operate at over synchronous speed, the requirement of great operating speed of control system to have the function extremum determined promptly (the ones presently used are too slow). Moreover, there are also problems to synchronize the operation in case of rapid and short-lasting wind blows or significant wind attenuation.

In Authors' opinion all the above mentioned disadvantages would get eliminated if the below presented system of induction generator cooperating with stationary (stiff) power network is used.

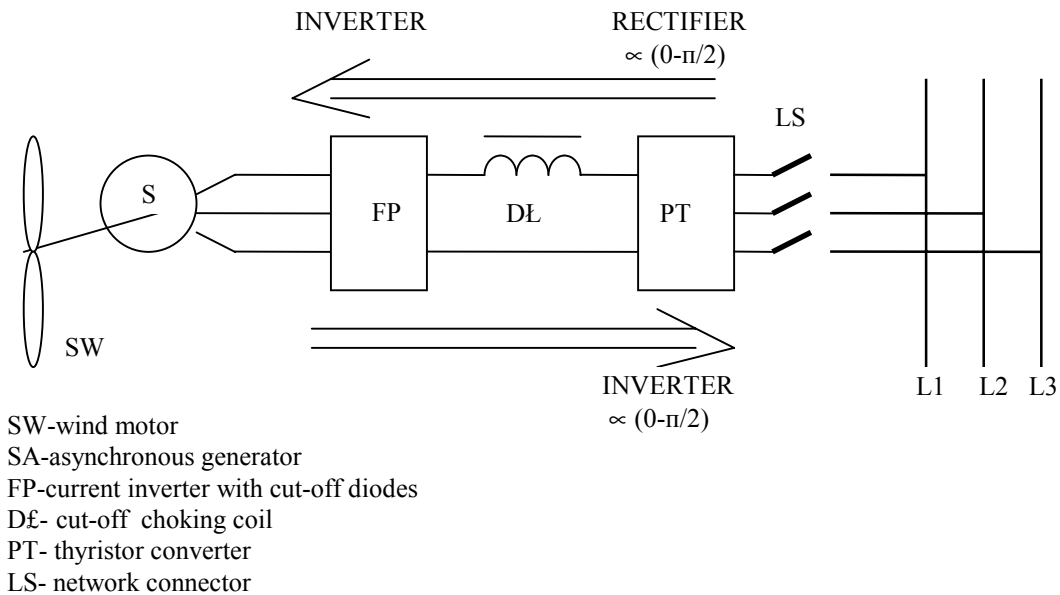

Fig.3 Diagram of wind generator coupling (SA - FP - PT - network)

The solution should appear advantageous (Fig.4) if the generator operates **only** in favour of the stationary (stiff) network. It would enable to motor start-up of the wind motor. The motor operation of generator SA is vital to reach such a rotation speed of the wind motor SW that the switching into generator operation mode is possible (lack of start-up moment). In this operation mode the thyristor converter PT works in rectifying operation range whereas current inverter with cut-off diodes FP operates as typical current inverter energizing the generator SA (Fig.4a). The energy is received from the power network and transferred to generator SA that drives the wind motor SW. Further on, the smooth turn into generator operation may be achieved that would maintain the advantageous generator stream-current mode in the asynchronous generator SA. In this operation mode the energy from wind motor is transferred through generator SA and the cur-

rent inverter FP to an intermediate direct current circuit comprising the cut-off chocking coil DL whereas the converter PT is adjusted for inverting operation mode, i.e. $\alpha > \pi/2$ (Fig.4b). Additional recommendation for the application of this solution is the characteristics of wind motor in which the power generated depends in the third power on the wind speed. It gives significant power alterations at relatively small wind speed change. The typical range of wind speed changes in terms of 1:10 rate results in power change rate as much as 1:1000. In this conditions the system SA-FP proves its usefulness.

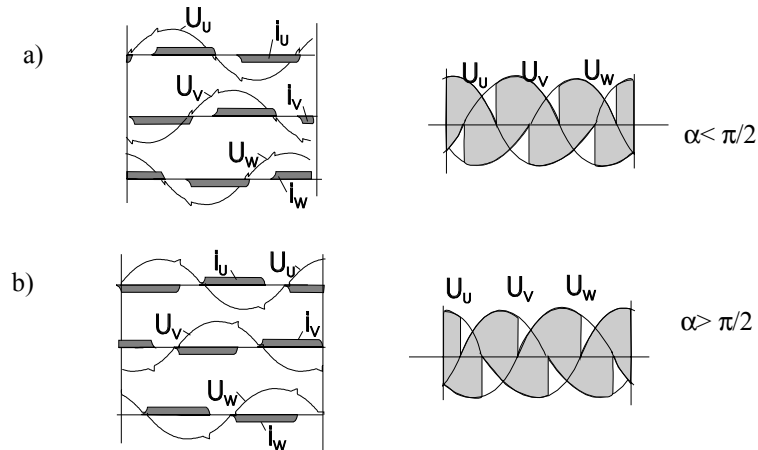

Fig.4 Courses of voltages and currents in system proposed a) motor start-up b) generator operation

Complete schematic diagram of the solution proposed has been presented at Fig.5.

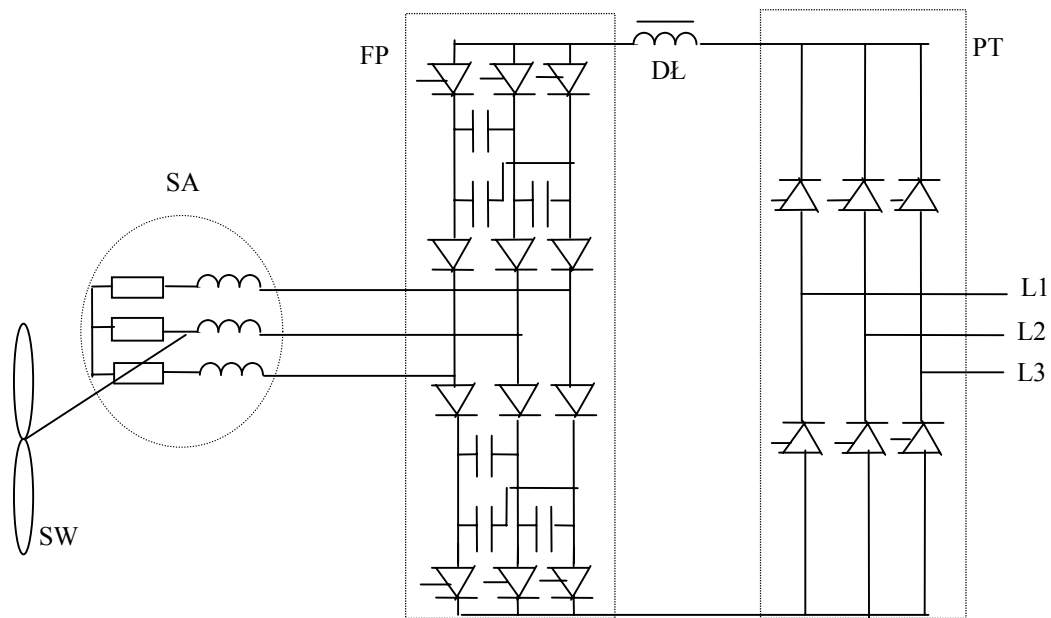

Fig.5 Schematic diagram of the solution proposed

However, considering the range of loads and frequency changes some problems, concerning the maintenance of low overvoltage levels and proper commutation capacitors selection, still remain. The Authors suggest to consider the system providing linear power transfer ensuring clear, sinusoidal shaped courses (system SA-FN1-2NS-FN2-network) either in case the system works for stationary network or for an autonomous receiver. The latter will be presented in publi-

cations to be issued later on.

3. CONTROL SYSTEM

The wind power plant system is characterized with high inertia and great difficulty to have it regulated. In case of standard wind power plant regulating systems the above properties, being the result of atypical forcing signal - the wind, usually require joint action with complicated mechanical and electromechanical systems. Such systems, aiming at increasing failure free and safer operation, procure the costs of standard wind power plant to be as high as mentioned in the Introduction of this paper.

The Authors of this article assert that taking present advanced technologies into account, the part of complicated, unitary and costly mechanical systems can be replaced, simplified or even eliminated. To achieve this goal the more complicated control system should be designed, using standard and thereby cheap electronic elements operating on base of a given software algorithm of adaptation characteristics involving fuzzy logic [1,2].

3.1 Brief Operating Algorithm of Wind Power Plant Control System

Having the control system switched on is equivalent to carrying out the functional diagnosis (start procedure of the controller) and technical diagnosis (complete tests) of the controller as well as to have the motor reached the generator operation point (preliminary retrieval of data). The main task of this phase is: to provide system configuration (manual or requested, restored from EPROM) and confirm its validity, to verify technical operating capability of the controller and actuators, to check the presence of the medium to drive the windwheel blades (wind), powerful enough to make the motor operate in generator operating mode (e.g. speed at least 3 m/s) within a given time period, and finally to start the motor using power supply of stationary network. An error in configuration, depending on its nature or location (microprocessor fault, memory fault, read error, etc.) may cause: system restart, alarm or emergency shut-down. Topologic error free configuration enables to carry out complete technical tests of both the controller (tests of I/Os, memory, etc.) and actuators or measuring devices (verification of ranges restored during configuration phase e.g. of tachometric generator).

The presence of the wind of expected speed, on having the wind power plant coupled (interconnected), causes the motor to start in motor operating mode (see the chapter "Operating system of wind power plant"). When the torque gets transferred from windwheel blades onto the machine shaft, that makes revolution number to increase to over n_o (for a given time), the generator operating mode starts automatically (thyristor angle control, change from converter function into inverter one).

The lack of the wind of expected speed causes a certain error message displayed and entering standby mode: awaiting either operator's decision or wind occurrence with required blow speed, without starting the motor. In case the wind speed exceeds 15 m/s (hurricane) a part of fuzzy unit operates as typical controller, i.e. the wind power plant gets cut off from stationary network (that ensures no current induction in motor windings and protection against its thermal damage) and the windwheel blades get stopped (that protects the motor and other power plant units against mechanical damage).

All the above described functions, established in configuration phase, are performed by fuzzy block containing the set of microprocessor instructions and descriptions of actions to undertake in situations prepared for by the operator. When an unexpected conditions appear the effects

should be similar or even identical to effects in situations being predicted (e.g. the effect of unexpected resistance of motor operation due to blades or bearings damage is the situation similar to wind decay, the case that is described with proper comment and remedy procedure thereof).

There are several main advantages of the proposed method using fuzzy logic that include the following: the increase of safety of the process controlled and the controller itself by decreasing or entire elimination of external hazard impacts or service faults, the increase of controlled process quality (particularly if the system works for an autonomous receiver), the minimization of controlling signal energy, the increase of controller applications, including its operation as typical controller and finally the chance to continue operation in emergency situations prerecognized.

An analogous operation algorithm of a wind power plant - in form of a block structure, including detailed description of particular block functions (for the wind power plant basing on a multi-run asynchronous machine) the Readers may find in publication [1].

4. ACKNOWLEDGMENTS

The Authors would like to express hereby their acknowledgments to Director of the Institute of Meteorology and Water Management in Gdynia, Poland for giving them free access to the data on wind speed measurements within the Region of Szczecin.

Moreover, particularly kind acknowledgments are to be pertained to Dr Eng. S. Turowski for his helpful assistance in collecting the data for this article.

5. BIBLIOGRAPHY

1. Barzyk G., Jarmusz M. *Projekt optymalizacji pracy układu siłowni wiatrowej przy zastosowaniu mikroprocesorowego regulatora wykorzystującego procedurę weryfikacji doboru nastaw*. Mat. III Międzynarodowej Konferencji Energetyków, Ustronie 1997 /in Polish/
2. Barzyk G., Jarmusz M. *Utilization of methods of control systems active diagnosis for improvement of control quality coefficients*. Preprints of 2ISTC UEES - Szczecin-Międzyzdroje 1996, vol.2
3. Jagodziński W. *Silniki wiatrowe*. Warszawa 1959
4. Krzemiński Z., Was M. *Control of over synchronous cascade applied in variable speed electrical power generator*. Preprints of 2ISTC UEES - Szczecin-Międzyzdroje 1996, vol.1
5. Opracowanie OGa/Ex/533-167/97, IMGW, Gdynia 1997
6. Stout B.A. *Handbook of energy for world agriculture*, London 1989
7. Tunia H. *Układy energoelektroniczne*, Warszawa 1982
8. Turowski S., Nowowiejski R. *The squirrel-cage induction motor as an asynchronous generator in the wind power plant*, Preprints of 2ISTC UEES - Szczecin-Międzyzdroje 1996, vol.2

ПРОСТАЯ И БЕЗОПАСНАЯ СИСТЕМА РАБОТЫ ВЕТРОВОЙ ЭЛЕКТРОСТАНЦИИ РАБОТАЮЩАЯ С ГОСУДАРСТВЕННОЙ СЕТЕЙ

Ключевые слова: электроэнергоэлектронные системы управления, употребление тиристоров, мягкая логика (fuzzy logic)

Резюме: В статье авторы показали дешёвые и безопасные системы работы ветровых электростанции. Подано свойства систем работы ветровых электростанции. Подано возможности их стройки в условиях Западной Померании (Польша). Представлено характеристики скорости ветров на этой территории в годах 1987-1996.